

TELEIOS OMNI PRO

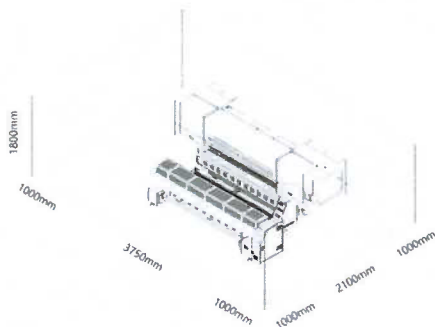

d.gen's best seller machine returns with an unprecedented Color Boosting Solution

- The most effective color enhancing method for pigment printing
- Extended options of printable substrates
- Enhanced colors and rub-off fastness with in-line HeatMan fixation units
- High definition and high productivity with new stated-of-the art industrial print heads
- Best performance guaranteed for soft-signage applications



TELEIOS OMNI PRO SPECIFICATIONS

TELEIOS OMNI PRO SPECIFICATIONS	
Printing	
Print head	Ricoh Gen6
Number of printheads	5
Configuration	5 printheads inline
Colors	6 (2 colors per printhead)
Number of Nozzles / colors	640 nozzles
Speed at 3 pass [m2/h] 600 X 900	53
Speed at 4 pass [m2/h] 600 X 1200	42
Media	
System	roll-to-roll
Roll size (printable width) [mm]	1880
Roll weight [Kg]	40
Roll diameter [mm]	300
Core diameter feeder [mm] [in]	dual 50.8 and 76.2 mm (2 and 3 inches)
Core diameter take up [mm] [in]	dual 50.8 and 76.2 mm (2 and 3 inches)
Thickness [mm]	2
Soft-signage	
Ink type	Disperse
Available colors	C, M, Y, K, Lc, Lm, Or, Tur, SPC
Media	Polyester
Main applications	Soft Signage, Home & Auto Textile
Fashion and home-decor	
Ink type	Pigment + CBS (Color Boosting Solutions)
Available colors	C, M, Y, K, Or, Bl, Lc, Lm, Sc, Gr
Media	Cotton, linen, wool, polyester, viscose, polycotton and other blended fabrics
Main applications	Fashion, Home Textile, Accessories
Connectivity	
Interface	Gigabit Ethernet (1000Base-Tx)
Dimensions [w x d x h] [mm]	
Printer only	3720 x 1070 x 1670 mm
Fixation 74	3020 x 635 x 830 mm
Dryer (4heaters)	2475 x 625 x 750
Fume buster only	620 x 640 x 1570 mm
Footprint [w x d] [mm]	
Full set with fixation unit	4267 x 1860 mm
Weight [Kg]	
Printer	800 Kg
HeatMan 1800	500 Kg
Fume buster	180 Kg
Total Weight [Kg]	
Full set + HeatMan 1800	1480 Kg
Average Consumption [kW]	
Printer	1Ø AC 220~240V 8.85 A (1.947 kW)
Fixation 74	3Ø AC 380~415V 14.67 A (9.65 kW)
Dryer (4heaters)	1Ø AC 220~240V 24 A (5.28 kW)
Fume buster	included in fixation unit
Total Av. Consumption [kW]	
Full set + Dryer + Fixation 74	16.88 kW